



**OPERATION AND MAINTENANCE
INSTRUCTIONS FOR THE**

**NO CLOG
DUAL PATH[™]
SOLDER EXTRACTOR**

MODELS

**SX-20
SX-25
SX-30**

**SX-20V
SX-25V
SX-30V**

MANUAL NO. 5050-0131

Featuring

Thermo-Drive[™]
HEAT CONTROL

REV. C

GENERAL INFORMATION

START-UP ALL MODELS

- To operate the Solder Extractor (all models),
- place Solder Extractor in stand
 - set Temperature Control to 10
 - allow three (3) minutes warm-up time
 - reduce temperature. A temperature setting of $7\frac{1}{2}$ to $8\frac{1}{2}$ is normal for most desoldering tasks
 - use the Extractor

ASSEMBLING CHAMBER TO FRONT SEAL

Look through vents to assure that the Chamber seats properly on the Front Seal.

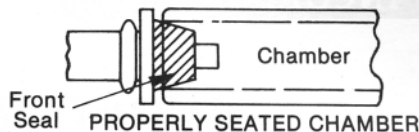

DESOLDERING ELECTRICALLY SENSITIVE COMPONENTS

Pace Power Sources with "Zero Power Switching" and all PED-A-VAC'S can be used with SX-20, SX-25 and SX-30 Desoldering Handpieces for safe removal of components. Power Sources without "Zero Power Switching" capability can safely remove sensitive components when used with the SX-20V, SX-25V and SX-30V Desoldering Handpieces. However, it is necessary to actuate the vacuum pump before the desoldering tip contacts the component lead, and continue the pump operation until the desoldering action is complete. Vacuum actuation is by finger tip control as described in this manual.

PROCEDURE FOR REMOVING GLASS CHAMBER

The Dual Path Solder Extractor is designed with a solder well which sits between the transfer tube and front seal tube (see illustration below). This feature contributes to the efficient operation of the Dual Path. Under normal operation, the well is maintained at a temperature above that of solder melt and therefore any solder falling into the well will remain molten. The following procedure should be followed before removing the Glass Chamber.

- While the extractor is hot, hold the extractor vertical, with the desoldering tip pointing straight-up.
- Gently tap the side of the extractor handle to loosen any molten solder that may be in the well so that gravity will flow the solder into the Glass Chamber.
- While still holding the extractor vertically, apply two or three blasts of vacuum as to suck any loose solder into the Glass Chamber.

You are now ready to remove the Glass Chamber from the Dual Path Solder Extractor for cleaning.

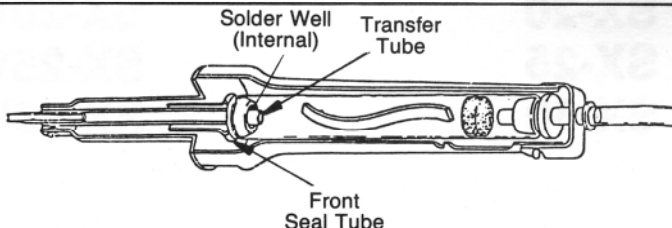

EQUIPMENT UPGRADING

If you own an old model Desoldering Tool and want to update it with a newer version, use Table 1 to choose an appropriate new Solder Extractor Model:

EQ 33 - 01
02
03

Table 1. OLD/NEW MODEL PACE PART NUMBERS

Old Model	Old Model Pace Part No.	Dual Path Model	New Pace Part No.
SX-199	7010-0017	SX-30	7010-0027
SX-199V	7010-0021	SX-30V	7010-0028
SX-200	7010-0004	SX-20	7010-0023
SX-200V	7010-0013	SX-20V	7010-0024
SX-201	7010-0011	SX-25	7010-0025
SX-201V	7010-0014	SX-25V	7010-0026

GENERAL INFORMATION

Before using your Dual Path™ Solder Extractor, read this manual to become familiar with its operation, capabilities, and maintenance. Used and maintained properly, your Dual Path Extractor will serve you well for many years.

TABLE OF CONTENTS

Title	Page
General Information	2
Theory of Operation	5
Operation	7
Maintenance	14
Replacement Parts	18

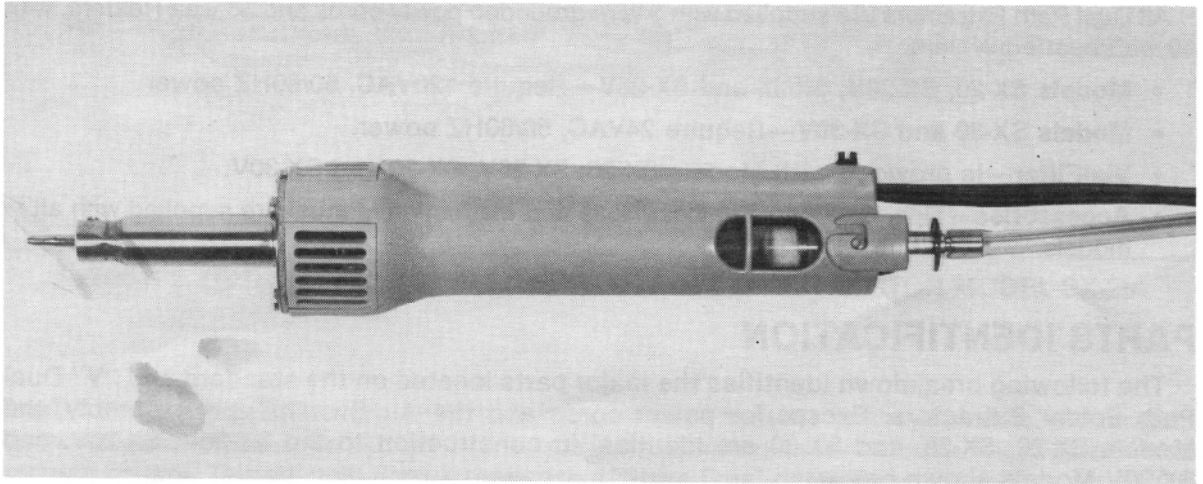

MODELS SX-20 — SX-25 — SX-30

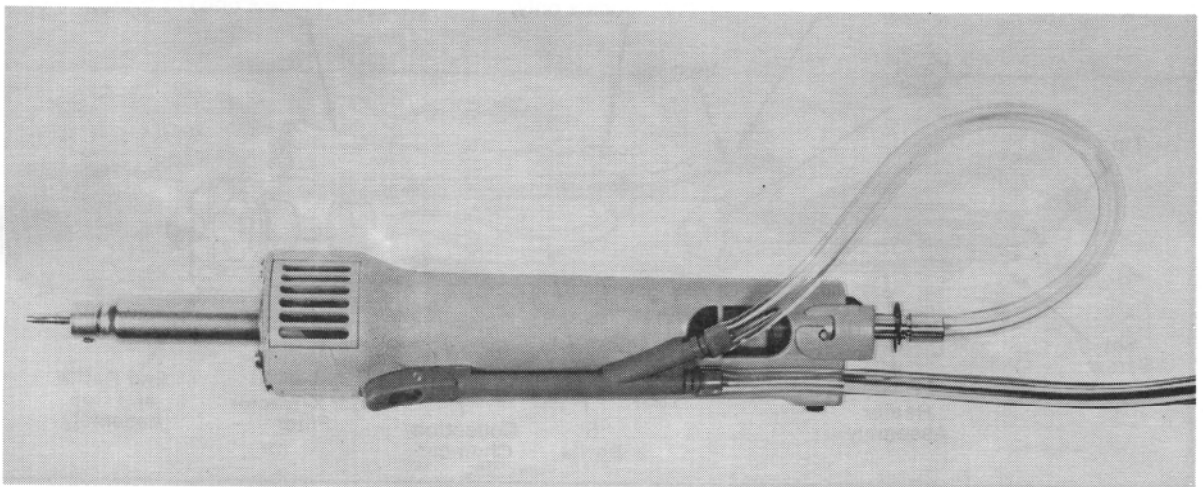

MODELS SX-20V — SX-25V — SX-30V
FIGURE 1. PACE DUAL PATH HANDPIECES

GENERAL INFORMATION

INTRODUCTION

Pace, Inc. is continuously improving its line of efficient and reliable instruments for the non-destructive rework, repair and modification of electronic assemblies. This manual describes six available Pace Solder Extractors and their uses.

Dual Path Solder Extractor Handpieces shown in Figure 1 work best with Pace Power Sources. They can be used with other power and vacuum sources, providing they have the required outputs.

SPECIFICATIONS

All Dual Path Extractors are supplied with 3 wire grounded power cords and 35 watt Heaters, with 60 watt heat equivalent.

- **Models SX-20, SX-20V, SX-25 and SX-25V**—Require 120VAC, 50/60HZ power.
- **Models SX-30 and SX-30V**—Require 24VAC, 50/60HZ power.
- **VisiFilter**—Is provided with Models SX-25, SX-25V, SX-30 and SX-30V.
- **Accessories**—Tips, Cleaning Brushes, Hose and Instruction Manual are supplied with all models.

PARTS IDENTIFICATION

The following breakdown identifies the major parts located on the standard and "V" Dual Path Solder Extractors. Except for power cords and the Air Switch/Tube Assembly, the Models SX-20, SX-25, and SX-30 are identical in construction to the SX-20V, SX-25V, and SX-30V Models shown below.

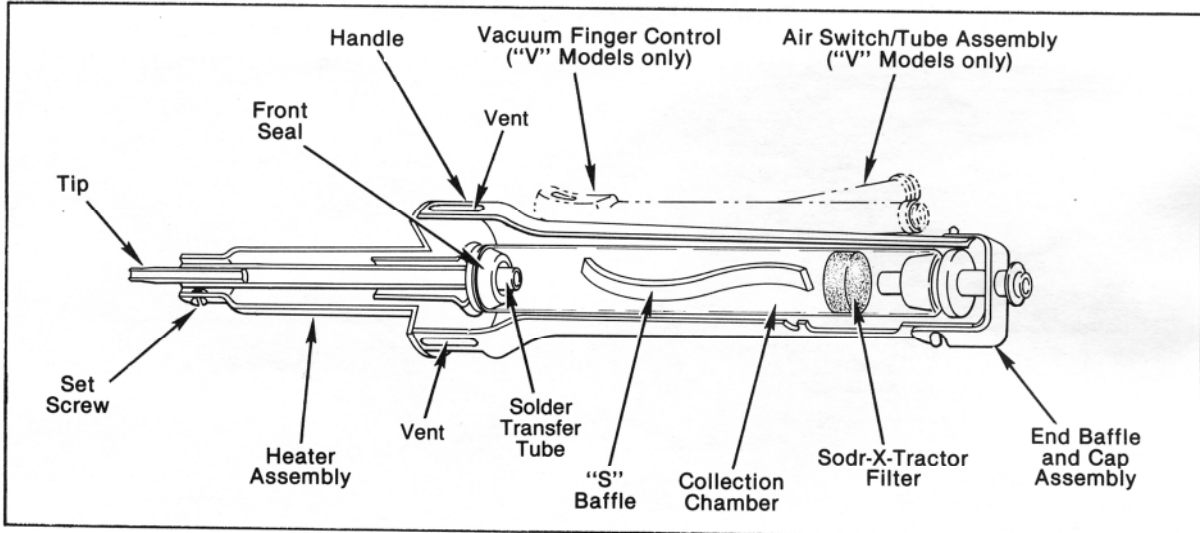

MODELS SX-20, SX-25, AND SX-30 PARTS IDENTIFICATION
MODELS SX-20V, SX-25V, AND SX-30V PARTS IDENTIFICATION

THEORY OF OPERATION

DUAL PATH SOLDER EXTRACTOR

The Solder Extractor functions as a vacuum cleaning device to remove solder. Heat supplied to the hollow tip (FIGURE 2) melts the solder, activating the vacuum flow which extracts the liquid solder from the joint and transfers it quickly and safely to the solder collection chamber within the handle.

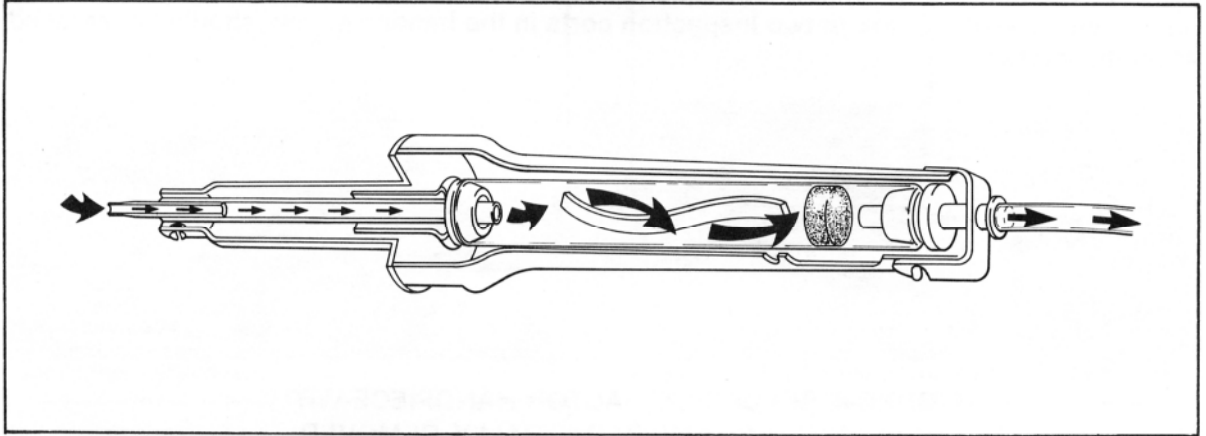

FIGURE 2. CUT-AWAY VIEW OF DUAL PATH SOLDER EXTRACTOR MODEL SX-25

The "V" Model Solder Extractors (FIGURE 3) have the same features as above Models, and an additional air switch/tube assembly to the handle for permitting instantaneous finger-tip-actuated vacuum control. This vacuum control gives users "Spike Free" desoldering capabilities for CMOS and similar static sensitive components (when used with power sources not equipped with electronic "Spike Free" Power™ output).

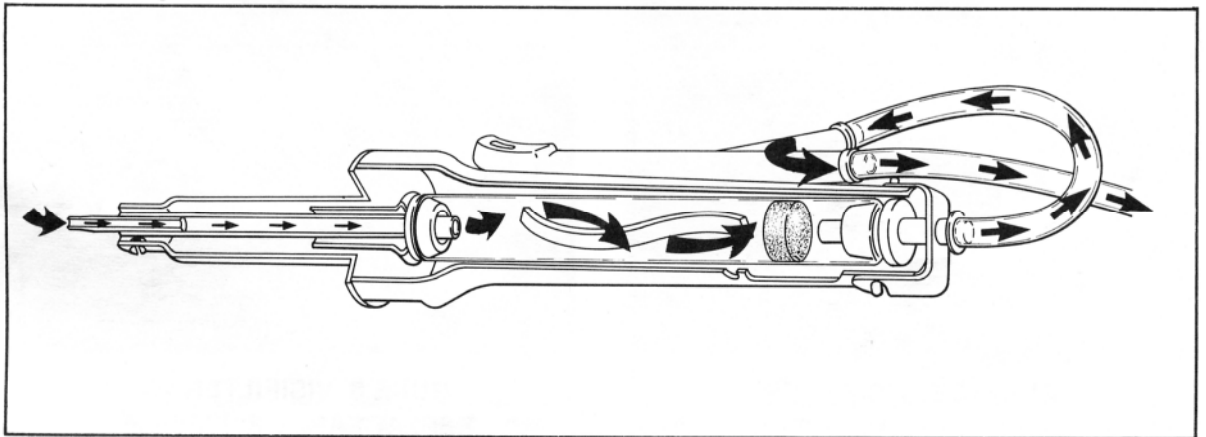

FIGURE 3. CUT-AWAY VIEW OF DUAL PATH SOLDER EXTRACTOR MODEL SX-25V

THEORY OF OPERATION

All Dual Solder Extractor models allow quick hand-removal of the solder collection chamber (FIGURE 4) for maintenance. The collection chamber is removed by a quick-twist without touching the hot chamber or of disturbing or disconnecting any heated elements or electrical connections. Ingested volatilized flux and coating are prevented from entering the pump or vacuum source by the primary filter at the inside rear of the glass chamber. This filter is easily visible through two inspection ports in the handpiece and should be replaced when discolored.

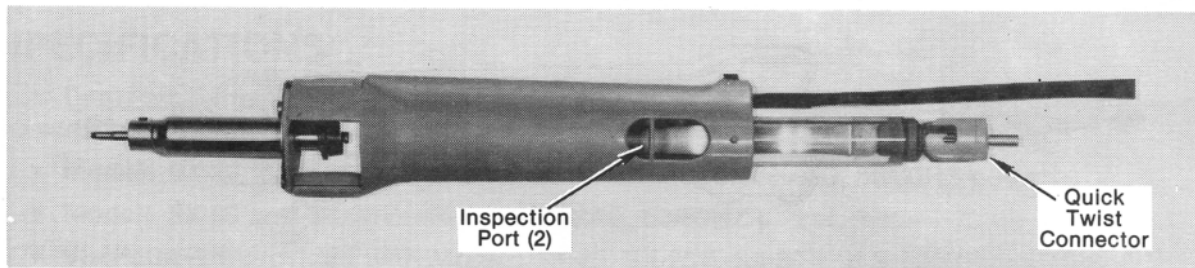

FIGURE 4. SOLDER EXTRACTOR HANDPIECE WITH COLLECTION CHAMBER PARTIALLY REMOVED

VISIFILTER™

An external filter (FIGURE 5) traps volatiles which are not handled by primary filter. VisiFilters are optionally available with replaceable filter elements, (FIGURE 6). Replace VisiFilter or Element when heavily discolored.

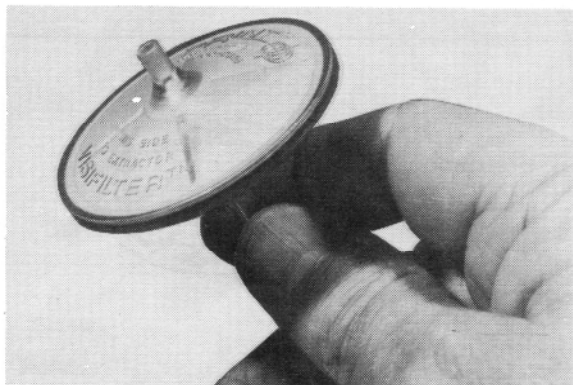

FIGURE 5. VISIFILTER

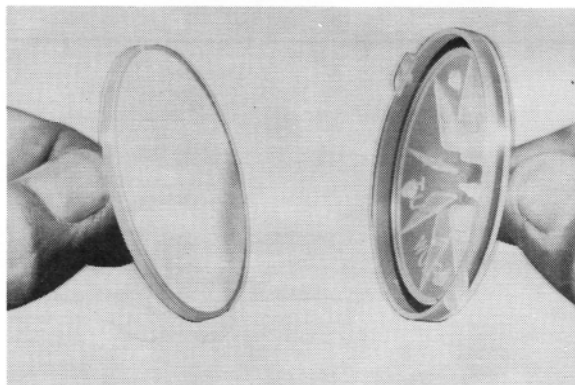
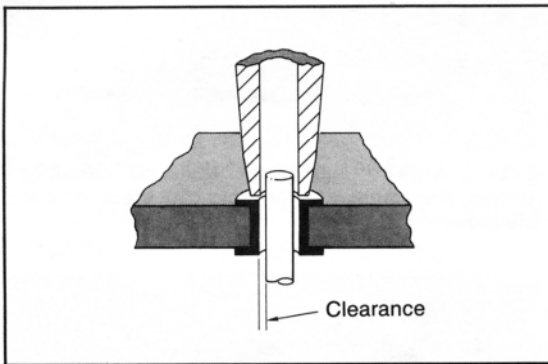

FIGURE 6. VISIFILTER WITH REPLACEABLE ELEMENTS

OPERATION

TIP SELECTION GUIDE

One of the most important aspects for successful solder extraction is the selection of the proper size of Tip for the job. Keep several points in mind while selecting the Tips:



STEP 1. The Inside Diameter (I.D.) of the Tip must be large enough to fit loosely over lead to provide clearance for air and molten solder flow.

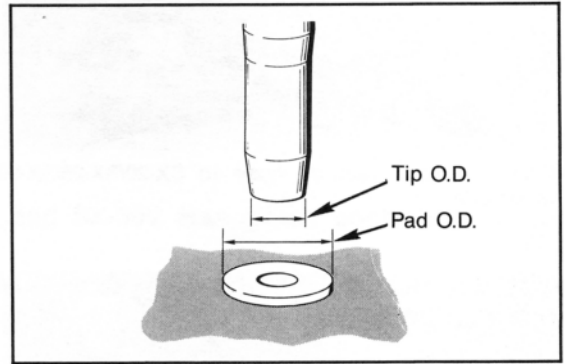

STEP 2. The Outside Diameter (O.D.) of the Tip must be smaller than the pad diameter to permit contact with the copper pad while preventing contact with the base material.

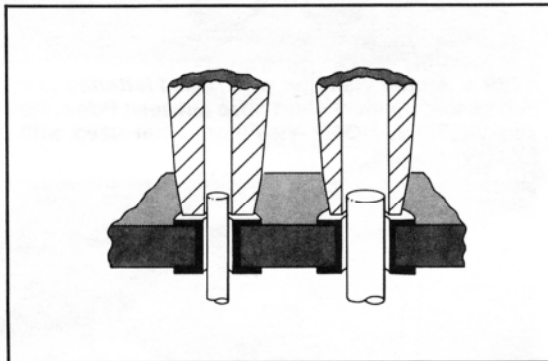

STEP 3. Match the Tip to the work. Small I.D. Tips for small leads, larger Tips for heavier leads.

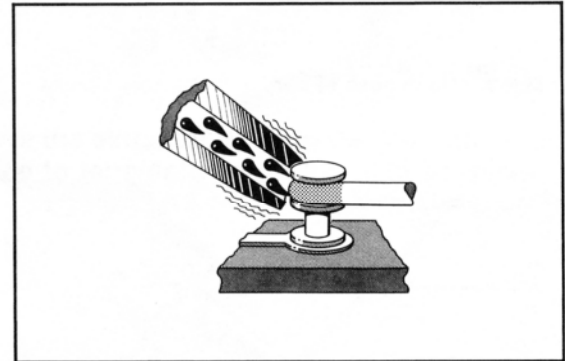

STEP 4. For desoldering terminals and solder splash removal, use largest I.D. Tip available.

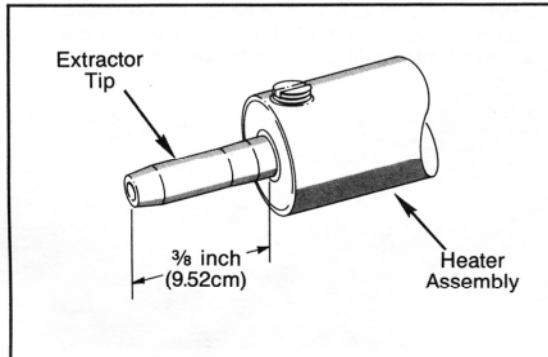

STEP 5. Adjust the selected Tip to extend approximately $\frac{3}{8}$ inch (9.52cm) beyond the heater body for all normal desoldering tasks.

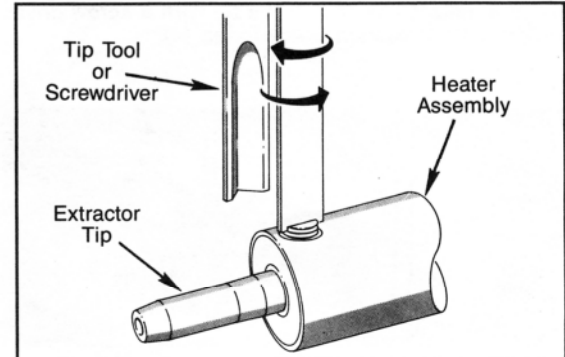

STEP 6. Tighten retaining screw approximately $\frac{1}{8}$ turn after screw contacts Tip. **DO NOT** overtighten.

OPERATION

SET-UP

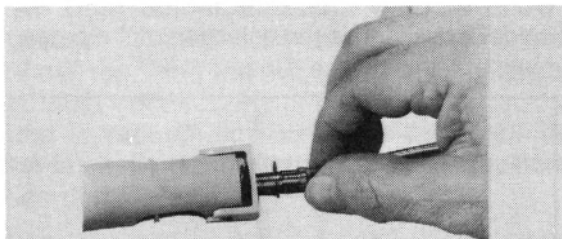

STEP 1. Attach vacuum hose to SX-20/SX-25/SX-30 handpiece.

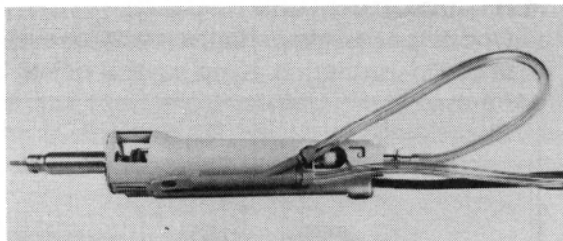

STEP 2. Attach hoses to the "V" Model handpiece as shown. Assemble the separate 12" piece of hose included.

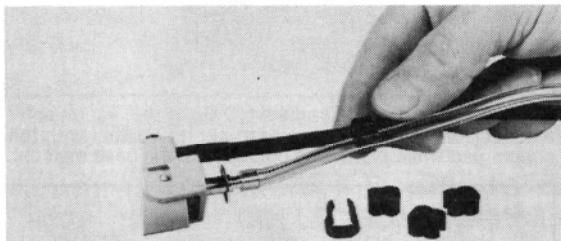

STEP 3. Attach hose to cord with retainer clamps.

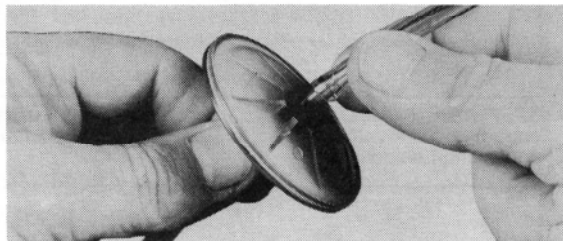

STEP 4. Attach VisiFilter with *raised lettering* towards handpiece. Connect short hose between Power Source and VisiFilter. NOTE: VisiFilter is not used with the SX-20(V) models.

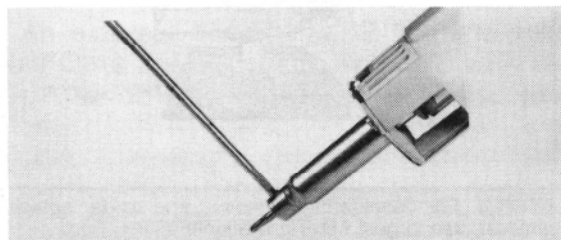

STEP 5. Select and attach the tip with a screw driver. Refer to Tip Selection Guide (page 14).

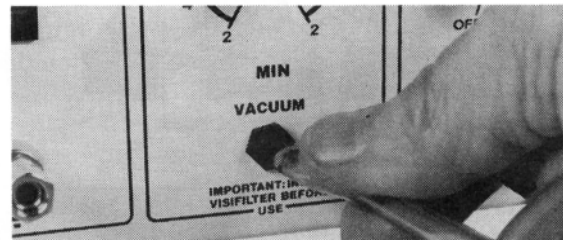

STEP 6. Attach air/vacuum hose to Power Source. Use maximum vacuum available. Optional air hose fittings are available to fit all Pace Power Sources.

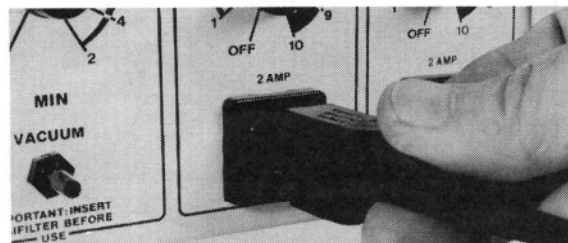

STEP 7. Plug in line cord to controlled Power Source outlet. Model SX-25 uses 120VAC 50-60HZ supply; Model SX-30 uses 24VAC 50-60 HZ supply.

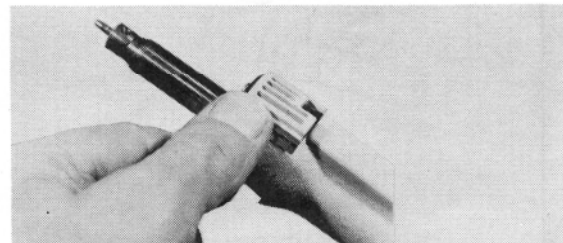

STEP 8. Solder Extractor vents may be replaced without removing heater assembly

INITIAL START-UP ALL MODELS

To operate the Solder Extractor (all models),

- a. place Solder Extractor in stand
- b. set Temperature Control to 10
- c. allow three (3) minutes warm-up time
- d. reduce temperature. A temperature setting of 7½ to 8½ is normal for most desoldering tasks
- e. use the Extractor

V-MODEL OPERATION

To operate the "V" Model SX-20V, SX-25V and SX-30V Handpiece controlled vacuum Extractors:

- a. Hold the handpiece as you would hold a pencil (FIGURE 7). Hold your index finger bent, with the tip of the finger resting firmly on the flat portion of the Vacuum Control Bar, and just behind the orifice.
- b. On the Power Source, turn Pump switch to the "ON" position (Refer to Operation and Maintenance Instructions for your Power Source).
- c. To actuate the vacuum, slide your finger tip firmly forward to completely seal the orifice. As long as the orifice is closed, the vacuum is actuated through the Sodr-X-Tractor tip. Keep moving the component lead with the Solder Extractor tip during full vacuum operation. Continue stirring lead to cool down the joint.
- d. After extracting the solder, remove the extractor tip from the joint, then slide your finger tip back off the orifice to terminate the vacuum. (If operation is completed, turn off pump. See Operation and Maintenance instruction for your Power Source).

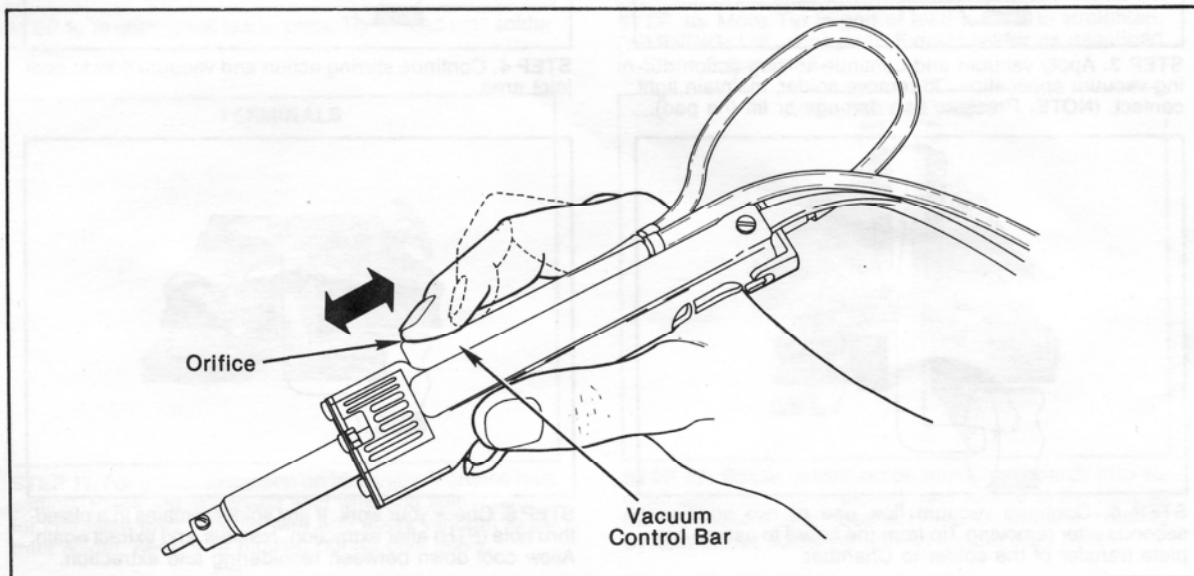
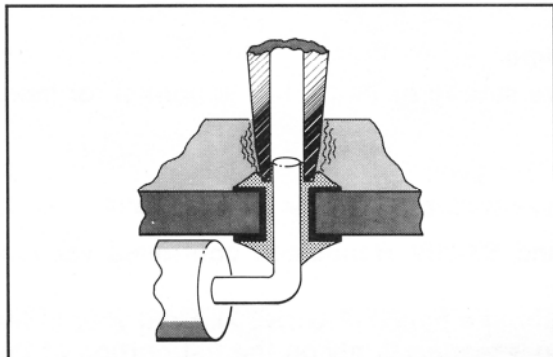

FIGURE 7. CORRECT POSITION FOR HOLDING THE HANDPIECE

OPERATION

VACUUM EXTRACTION

When performing a desoldering operation, the following steps should be followed for best results.



STEP 1. Position the Tip over the lead making contact with solder. As the solder melts, allow the Tip to gently rest on a film of solder between solder and Tip.

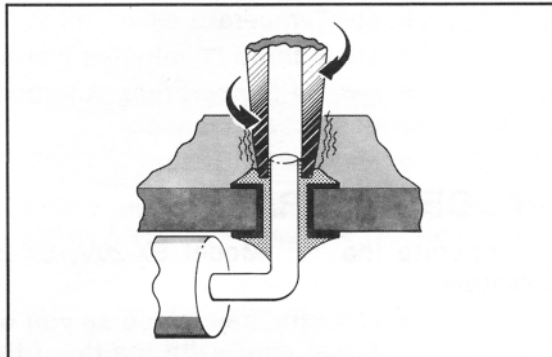

STEP 2. Move Tip with a stirring motion, dwelling until lead moves freely within the board hole. Free movement of the lead indicates complete solder melt.

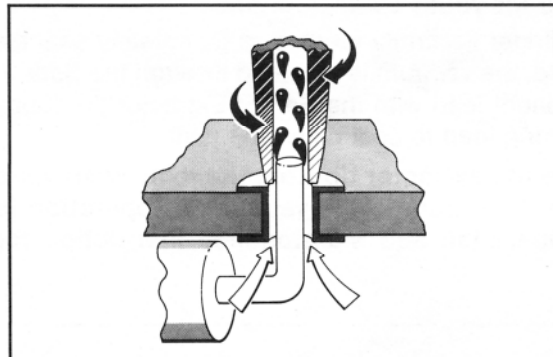

STEP 3. Apply vacuum and continue stirring action during vacuum application. To remove solder, maintain light contact. (**NOTE:** Pressure can damage or lift the pad).

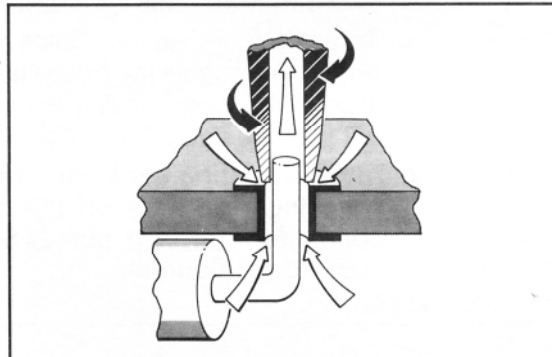

STEP 4. Continue stirring action and vacuum flow to cool joint area.

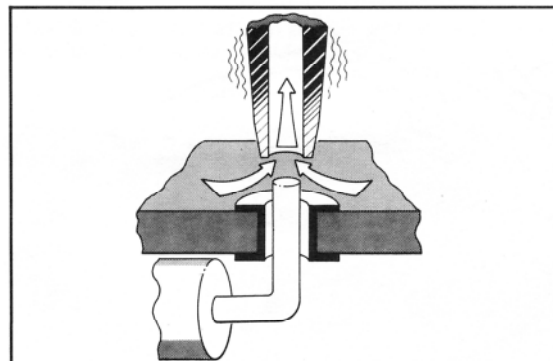

STEP 5. Continue vacuum flow one or two additional seconds after removing Tip from the board to assure complete transfer of the solder to Chamber.

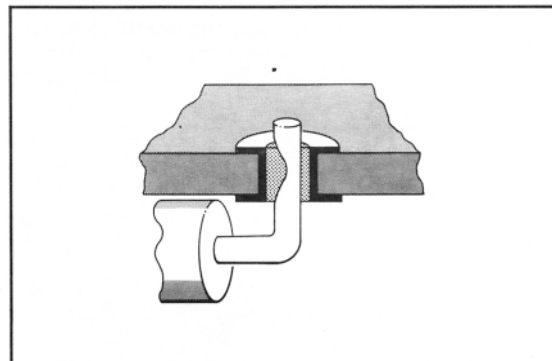

STEP 6. Check your work. If any solder remains in a plated-thru hole (PTH) after extraction, resolder and extract again. Allow cool down between resoldering and extraction.

VACUUM EXTRACTION (continued)

HOT-AIR PRESSURES

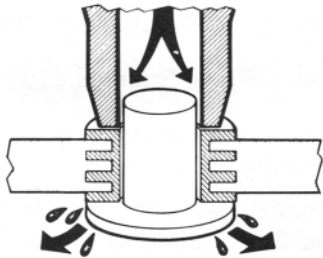

STEP 7. Hot-air pressure mode removes solder from blind of thru-hole joints.

HOT-AIR PRESSURES



STEP 8. Hot-air jet mode melts planar component leads, solder connections and shrinks tubing.

CLINCHED LEADS

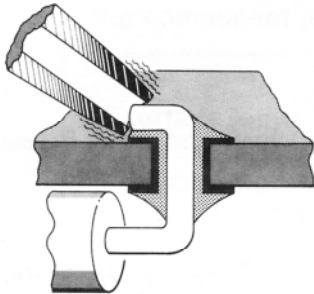

STEP 9. To unclinch leads, place Tip on lead until solder melts.

CLINCHED LEADS

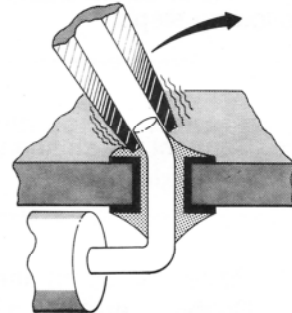

STEP 10. Move Tip to end of lead and lift to straighten. (**WARNING:** Lift, don't pry!). Extract solder as described in Steps 3 through 6.

TERMINALS

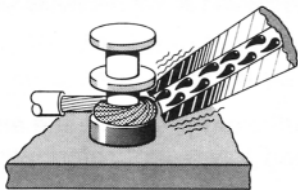

STEP 11. For solder extraction on terminals, increase heat setting. Place Tip in contact with wire and solder. Watch for complete melt. Wiggle wire and apply vacuum to extract solder. Keep wire moving during cool down.

AUXILIARY HEATING

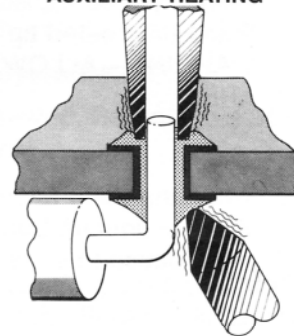

STEP 12. Solder extraction on multilayer boards may require application of a second heat source at the joint on the convenient side. Use a PACE Conductive Heating System or hot soldering iron tip for auxiliary heat.

OPERATION

PRESSURE MODE (USE OF AIR PRESSURE)

The following procedures apply when the extractor is used with Power Sources equipped with a controlled air pressure outlet.

Circumstances may occur when the Vacuum Mode of operation will not completely remove a solder joint. This is most often the case when a "Blind-Sided Solder Joint" is found. The "Blind-Sided Solder Joint" is so named because of its inaccessibility, usually on the component side of the board. This is common when a terminal flanged end (on opposite side of board) blocks air flow. In this case the vacuum method is not applicable since no cooling air can be pulled through the hole thus causing a sweat joint. So in this case (see Step 7 on page 11; and steps below). The "Pressure Mode" is now required to break up this Blind-Sided Solder Joint. The "Pressure Mode" uses the following steps:

- a. Connect the air line to the Pressure Flow control valve and adjust Pressure control to "maximum".
- b. Place the tip of the Extractor into the "Solder Dump" between the two "Hot Cubbies", and use a burst of pressure to clear any molten solder which might be in the heater tube.
- c. Heat must be transmitted through the lead to melt the Blind-Sided Solder Joint. Place the heated tip over and in contact with the lead.
WARNING—ALLOW THE TIP TO COME INTO LIGHT CONTACT WITH THE PAD AREA.
- d. When the Blind-Sided Solder Joint is heated sufficiently, actuate the airflow to provide continuous burst of pressure. Stir the lead to prevent reformation of sweat joints caused by the continuing flow of air.

If conformal coating is blocking air flow, the coating must be removed before the vacuum desoldering operation. Try hot air jet to decure coatings; or thermo-plating tool to remove coatings (See hot air jet page 13.)

HOT AIR JET MODE

The hot air mode of operation is used for several different applications:

- **SURFACE SOLDERED JOINTS**

Surface solder joints are removed with the "Hot Air Jet Mode" of operation. The following steps should be taken for the successful removal of surface mounted components.

- a. With the air line connected to the Pressure Flow Control Valve on the Power Source, set Pressure valve and power to "MAX" and blow out excess molten solder.
- b. Reduce the Pressure valve setting to "MIN" and use .036 I.D. Tip.
- c. A carefully-directed Hot Air Jet will melt the solder joint when the tip is held approximately $\frac{1}{4}$ " from the surface. When you see the solder melt, lift the lead with a soldering aid or tweezers. Do not lift before melting is observed, or you might lift the pads from the substrate.
- d. Repeat this process for each individual lead until all leads are removed and the component is free.

GENERAL NOTE

If surface joints are heavily mounded with solder, it may be desirable to use the Vacuum Mode to remove excess solder prior to using Hot Air Jet Method.

- **HEAT SHRINKABLE TUBING**

To use Hot Air Jet Mode of Operation for shrinking tubing, apply the properly adjusted jet slowly along the entire length of the tubing. Do not play the hot air at one point, but evenly distribute heat to shrink tubing. Be sure all tubing has shrunk completely before allowing it to cool.

- **CONFORMAL COATING REMOVAL (Epoxy and Polyurethane)**

Apply Hot Air Jet to the conformal coating to be removed. Remove the softened coating with an orange stick so you won't damage the board.

- **REMOVAL OF BONDED COMPONENTS**

Apply Hot Air Jet to the component body and surrounding area to soften the bonding material. Then twist the component to be removed with pliers or tweezers. Heating may be required for 2 or 3 minutes, depending upon the size of the component and the thickness of the coating.

MAINTENANCE

TIP CARE

The Extractor Tips should be cared for in the same manner as soldering iron tips. The following suggestions will prevent damage to the handpiece assembly:

- Remove excess solder, burned flux, and conformal coatings by lightly wiping the tip on a non-contaminating material.
- The Solder Extractor Tip is expendable; washout (thinning) of the inside bore occurs during normal use. The Tip must be replaced before it becomes so thin that it breaks off in the heater assembly.
- Charred coating of flux can cause blockage in the tip bore. Clear the residue from inside the tip with a length of small-diameter stiff wire.

BROKEN TIP REMOVAL

If the tip breaks off in the Heater assembly, remove power cord from power source. Use a steel rod, slightly less than 1/8 inch in diameter, to ram the broken tip out of the Heater tube while the Extractor is still hot. With set screw removed, insert ram from handle end while the front face of the heater is supported and drive the broken tip out. (FIGURE 8)

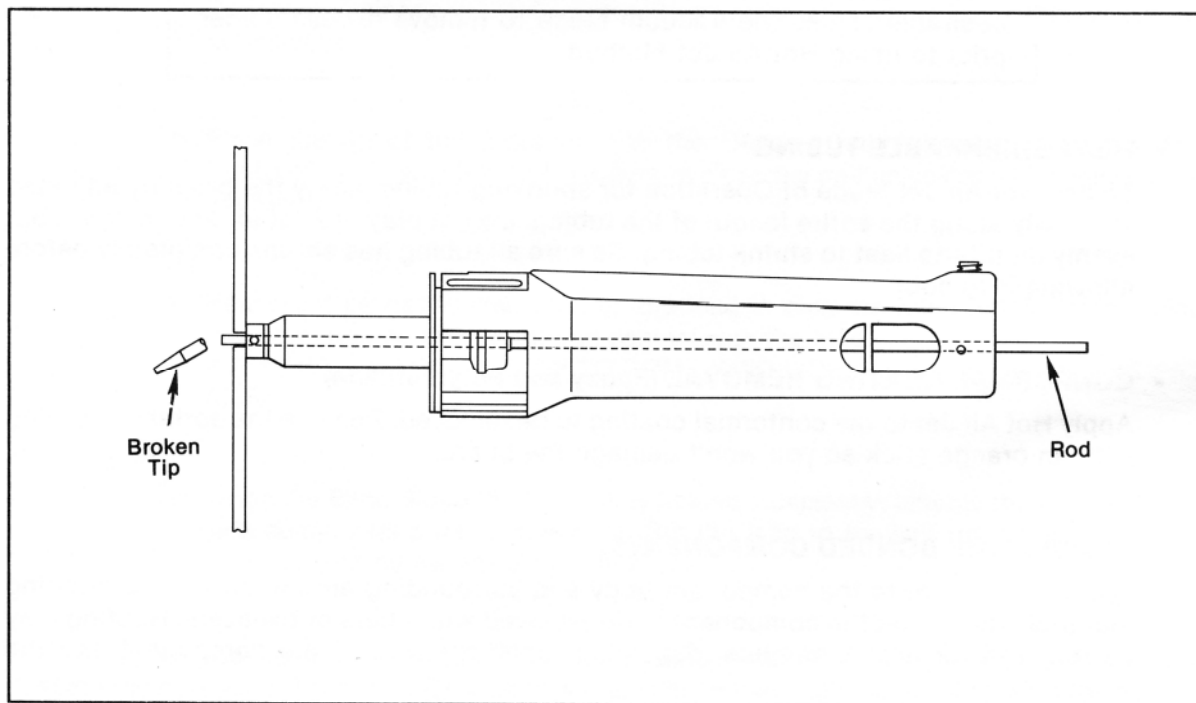

FIGURE 8. BROKEN TIP REMOVAL

TIP REPLACEMENT PROCEDURE

- a. While the unit is idling hot, loosen set screw to free the tip.
- b. Remove the Tip from the Heater.
- c. Clean Heater with small wire brush to remove oxide buildup.
- d. Place new Tip in Heater with hangout of $\frac{1}{2}$ to $\frac{5}{8}$.
- e. Tighten set screw $\frac{1}{8}$ turn past the point of contact to secure Tip in place.

NOTE

Although set screws are permanently lubricated, it is essential that the screw be loosened and the tip be removed at least once every eight operating hours.

CLEANING SOLDER COLLECTION CHAMBER

Solder and flux buildup in Chamber depends upon use. Clean Chamber and "S" Baffle as often as necessary with a large bristle brush. Apply mineral oil to the brush and lightly coat inside of Chamber and "S" Baffle.

REPLACING PRIMARY VISIBLE FILTER

The white, primary Sodr-X-Tractor Filter located within the rear of the Glass Chamber (FIGURE 9) should be changed whenever heavy deposits of contaminants are noticeable. It is very important that this filter be kept clean; this assures optimum air flow and minimum flow restriction, and keeps contaminants from reaching the vacuum source.

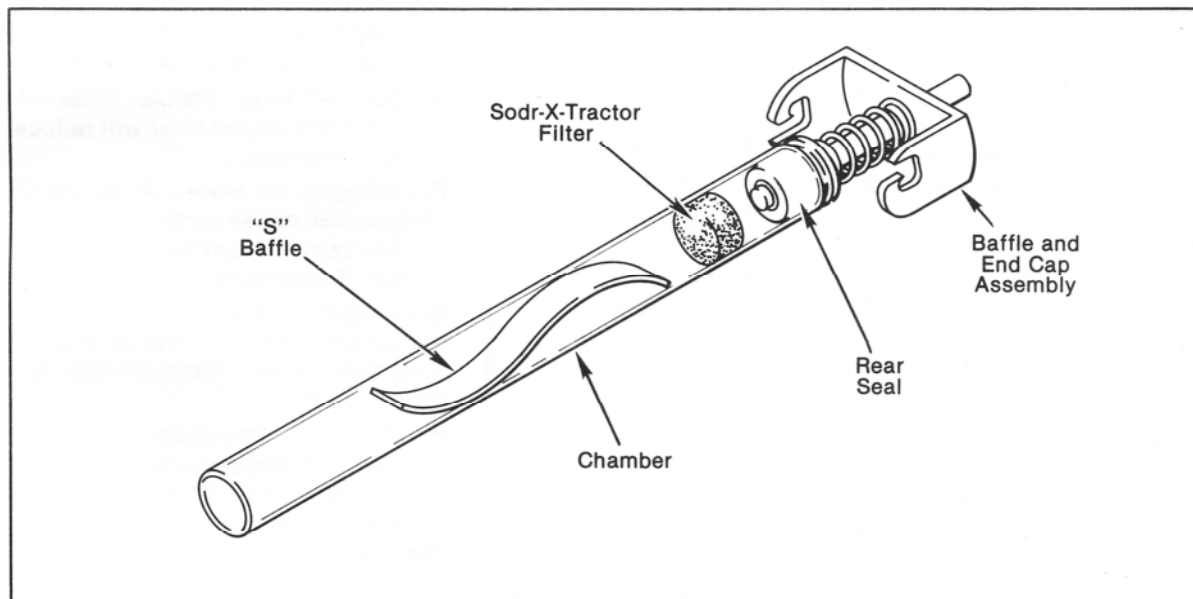

FIGURE 9. SODR-X-TRACTOR FILTER LOCATION.

MAINTENANCE

CORRECTIVE MAINTENANCE

Table (2) outlines the most common deficiencies which might occur and the easiest solution to each:

TABLE 2. CORRECTIVE ACTION FOR MOST COMMON MALFUNCTIONS

SYMPTOMS	CAUSE	SOLUTION
The operator notices that solder joints are not being completely removed on a consistent basis.	Loss of Vacuum	<p>A. Clean Tip bore.</p> <p>B. Clean Heater solder transfer with wire bristle brush.</p> <p>C. Check "S" Baffle. If the "S" Baffle has shifted within the Glass Tube to a position where it blocks the Transfer Tube, the vacuum could be reduced. It is important that the "S" Baffle have enough tension so that it maintains a constant position in the Chamber. This may be adjusted by bending the "S" Baffle between your fingers. DO NOT ATTEMPT TO BEND THE "S" BAFFLE WHILE IT IS IN THE GLASS CHAMBER. The Baffle should be seated just in front of the End Cap Baffle Assembly, leaving sufficient room for the Filter (refer to FIGURE 9).</p> <p>D. Front Seal—Assure that Chamber is properly seated on the front seal.</p> <p>E. Sodr-X-Tractor Visible Filter—A contaminant loaded filter will reduce air flow. Replace.</p> <p>F. Damaged Air Hose—A damaged air hose can cause partial or full loss of vacuum. Examine hose and replace if necessary.</p> <p>G. Clogged VisiFilter—Replace filter or filter element when filter is loaded. Dark discoloration indicates time for replacement.</p> <p>H. Clogged, Damaged Pump or Vacuum Transducer—Refer to your "Operation Maintenance Power Source or Vacuum Transducer" manual.</p>

MAINTENANCE

CORRECTIVE MAINTENANCE

TABLE 2. CORRECTIVE ACTION FOR MOST COMMON MALFUNCTIONS (cont.)

SYMPTOMS	CAUSE	SOLUTION
Heater does not heat.	No electrical power to heater.	A. Check power cords, is Power Source and Extractor plugged in power outlet? B. Turn "ON" power. C. Check Power Source Fuse, replace if blown.
Heater does not heat.	Defective Heater	A. Replace Heater Assembly (refer to FIGURE 10) 1. DISCONNECT POWER-CORD from outlet. Remove three screws in flange holding heater assembly to handle. 2. Loosen stress relief screw at rear of handle. 3. Slowly remove the heater by pushing the cord through the handle from the back end. Remove vent. Do not pull the heater assembly. 4. Remove the screw and nut-which attaches the ground wire to the heater flange. 5. Remove the rear seal and insulating washer. 6. Use pliers to grasp the connector pins attached to the heater wires. <i>Ease</i> each pin from its connector since pins are tightly fitted. 7. Remove front seal from replacement heater, assemble insulating washer over seal retainer tube, replace seal. 8. Attach ground wire firmly to heater flange. 9. Mount heater to handpiece. Clearance cutout is provided in insulating washer for ground screw.

REPLACEMENT PARTS

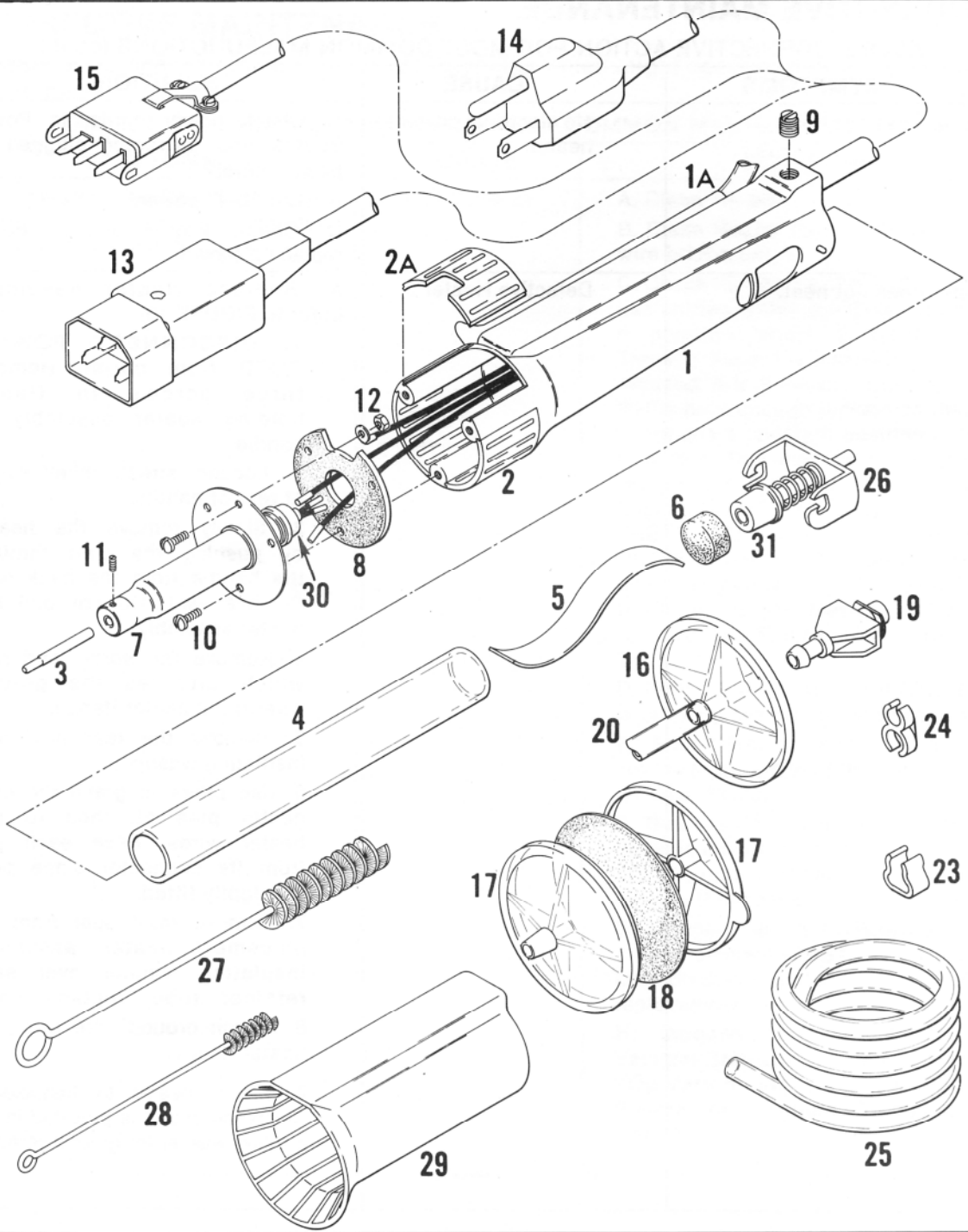

FIGURE 10. DIAGRAM OF REPLACEMENT PARTS

REPLACEMENT PARTS

TABLE 3. LIST OF REPLACEMENT PARTS FOR SOLDER EXTRACTOR
(Refer to FIGURE 10 for Item No.)

ITEM NO.	DESCRIPTION	PAGE PART NO.
1	Extractor Handle, SX-20, SX-25, SX-30	1119-0039
1A	Extractor Handle, SX-20V, SX-25V, SX-30V	1119-0050
2	Vents (2)	1119-0041
2A	Vent (1)	1119-0042
3	Super Tip	See Tip Chart
4	Glass Chamber	1265-0003
5	"S" Baffle	4010-0033
6	Sodr-X-Tractor Filter (Pk/10)	1309-0018
7	Heater and Seal Assembly, Dual Path 120VAC,35W	6010-0034
	Heater and Seal Assembly, Dual Path 24VAC,35W	6010-0035
8	Heater Washer	1213-0030
9	Screw, Nylon	1405-0341
10	Screw w/Lockwasher #4-40 x 5/16" SST (4)	
11	Set Screw (Pk/10)	1348-0285
12	Nut #4-40, Hex Head (1)	
13	Line Cord Assembly (VDE)	1332-0090
14	Line Cord Assembly, Standard (120VAC)	1332-0009
15	Line Cord Assembly (24VAC)	1332-0032
16	VisiFilter	1309-0020
17	VisiFilter, Replaceable Element Type	1309-0028
18	Filter Element, VisiFilter	1309-0027
19	Twist Lock Fitting	1263-0004
20	Tubing Assembly w/VisiFilter	1325-0017
21	Tubing Assembly w/Twist Lock Fitting	1325-0006
22	Tubing 12"	1342-0001
23	Clamp, Flat Cord Type	1211-0002
24	Clamp, Round Cord Type	1321-0085-02
25	Tubing, 6' Length	1325-0003
26	Baffle and End Cap Assembly, Dual Path	4010-0071
27	Bristle Brush	1127-0002
28	Wire Brush	1127-0006
29	Cushion Grip (fits standard handpiece only)	1346-0042
30	Front Seal	1213-0033
31	Rear Seal	1213-0001

REPLACEMENT TIPS FOR SOLDER EXTRACTOR

Table 4 lists replacement Tips used for the Solder Extractor. Use FIGURE 11 to determine the Outside Diameter (O.D.) and Inside Diameter (I.D.), then select the Tip part from Table 4.

TABLE 4. REPLACEMENT PART NUMBER FOR TIPS

	I.D. NOMINAL		O.D. REFERENCE		PAGE PART NUMBER
	in.	mm	in.	mm	
SUPER TIPS	.018	0.45	.053	1.34	1121-0213
	.025	0.63	.060	1.52	1121-0214
	.036	0.91	.072	1.83	1121-0215
	.050	1.27	.085	2.16	1121-0216
	.061	1.55	.104	2.64	1121-0217
	.095	2.43	.125	3.17	1121-0091

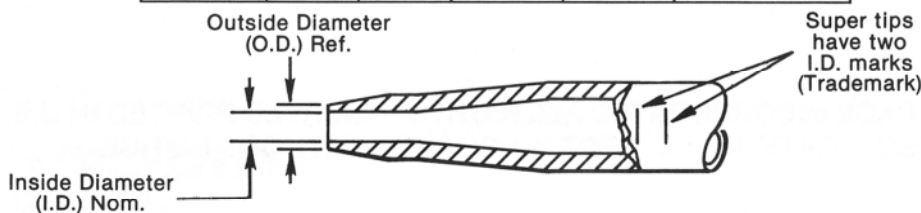

FIGURE 11. MEASUREMENT OF REPLACEMENT TIPS

PAGE[®]
INCORPORATED

**9893 BREWERS COURT
LAUREL, MARYLAND 20723-1990 USA
(301) 490-9860
FAX 301 498 3252**

**©1982 PACE INCORPORATED ALL RIGHTS RESERVED PRINTED IN U.S.A.
ALL SPECIFICATIONS SUBJECT TO CHANGE WITHOUT NOTICE**